

LAUREL MOUNTAIN WHIRLPOOLS

# DUAL CORNER PLUS

DUAL PLUS	WHIRLPOOL	6060DPW L/R*
DUAL PLUS	AIR BATH	6060DPA L/R*
DUAL PLUS	COMBO BATH	6060DPWA L/R*
DUAL PLUS	TUB ONLY	6060DPT L/R*

INSTALLATION NOTES: Install this fixture according to the installation manual. Confirm specifications before starting installation.

ELECTRICAL REQUIREMENTS: Whirlpool pump/motor 120V, 20A, 60HZ, Air Blower/Heater 120V, 20A, 60HZ. Dedicated GFCI required.

\* Left or Right Drain

All dimensions are +/- 1/4" and subject to change without notice.

Available with an optional attachable skirt with removable access panel.

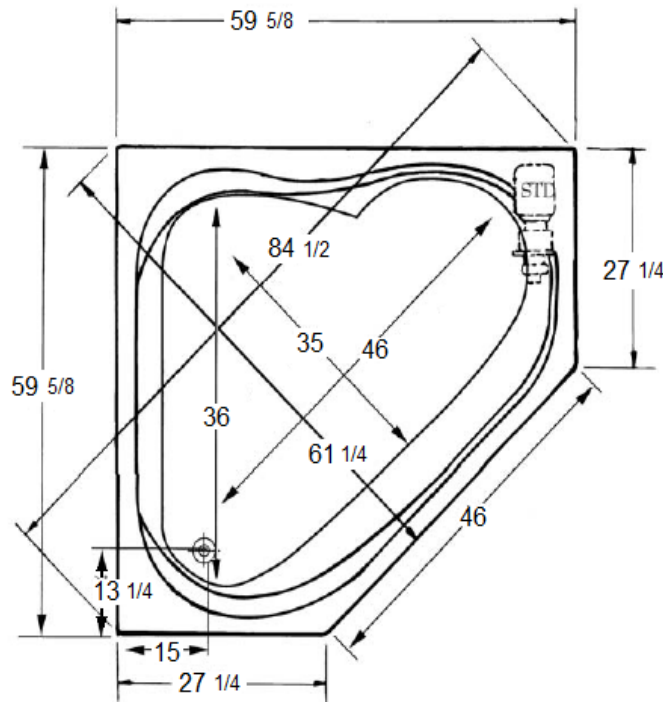

SPECIFICATIONS	WHIRLPOOL AIR/COMBO	SOAKER
59 5/8" x 59 5/8" x 27 1/4" x 27 1/4" x 46" x 20"	Lip 2"	
Water Capacity - Operating Level .....	48.0 gal.	
- To Overflow .....	78.0 gal.	78.0 gal.
Approx. Unit Weight.....	170.0 lbs.	135.0 lbs.
Water Depth to Overflow .....	14 3/4"	14 3/4"

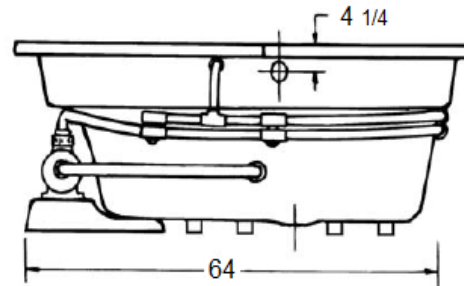
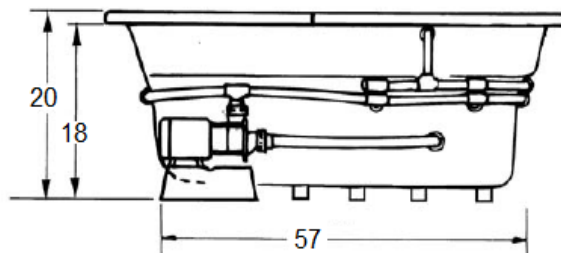

Website: [www.laurelmountainwhirlpools.com](http://www.laurelmountainwhirlpools.com)  
 Email: [sales@laurelmountainwhirlpools.com](mailto:sales@laurelmountainwhirlpools.com)  
 Phone: 800-930-0050  
 Fax: 800-930-0051

Manufacturing Facility  
 1610 James P. Rodgers Drive  
 Valdosta, GA 31601

Sales/Customer Service  
 26 Nesbitt Rd. Suite 257  
 New Castle, PA 16105