

DUAL CORNER PLUS

DUAL PLUS WHIRLPOOL	6060DPW L/R*
DUAL PLUS AIR BATH	6060DPA L/R*
DUAL PLUS COMBO BATH	6060DPWA L/R*
DUAL PLUS TUB ONLY	6060DPT L/R*

INSTALLATION NOTES: Install this fixture according to the installation manual. Confirm specifications before starting installation.

ELECTRICAL REQUIREMENTS: Whirlpool pump/motor 120V, 20A, 60HZ, Air Blower/Heater 120V, 20A, 60HZ. Dedicated GFCI required.

* Left or Right Drain

All dimensions are +/- 1/4" and subject to change without notice.

Available with an optional attachable skirt with removable access panel.

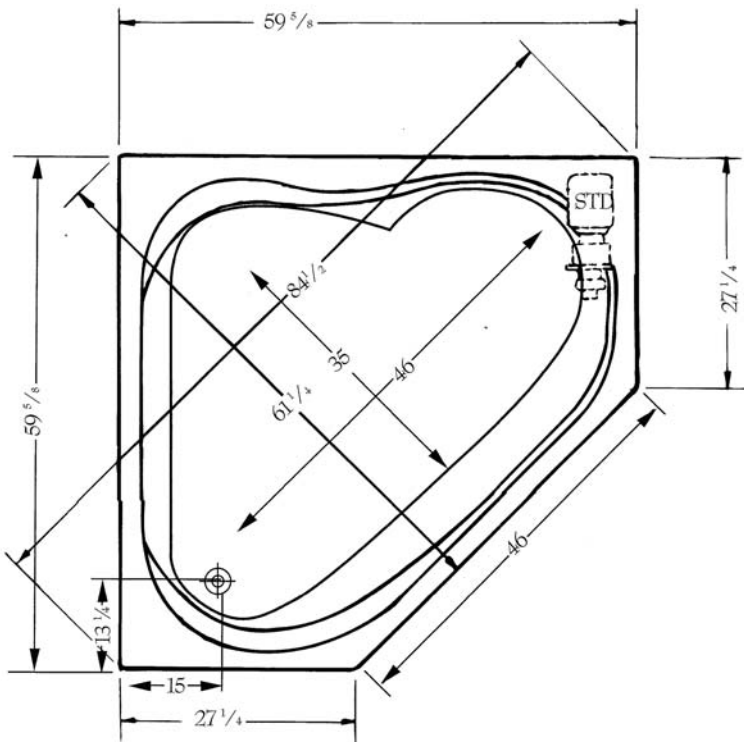

SPECIFICATIONS	WHIRLPOOL AIR/COMBO	SOAKER
59 5/8" x 59 5/8" x 27 1/4" x 27 1/4" x 46" x 20" Lip 2"		
Water Capacity - Operating Level	48.0 gal.	
- To Overflow	78.0 gal.	78.0 gal.
Approx. Unit Weight.....	170.0 lbs.	135.0 lbs.
Water Depth to Overflow	14 3/4"	14 3/4"

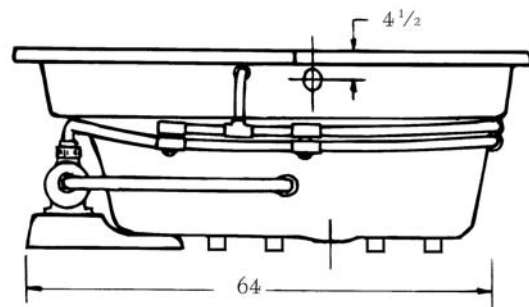
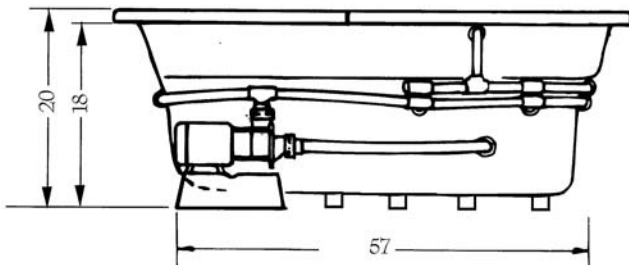

Website: www.laurelmountainwhirlpools.com
 Email: sales@laurelmountainwhirlpools.com
 Phone: 800-930-0050
 Fax: 800-930-0051

Manufacturing Facility
 1610 James P. Rodgers Drive
 Valdosta, GA 31601

Sales/Customer Service
 2418 Wilmington Road, Suite C
 New Castle, PA 16105