

SUBMITTAL DATA

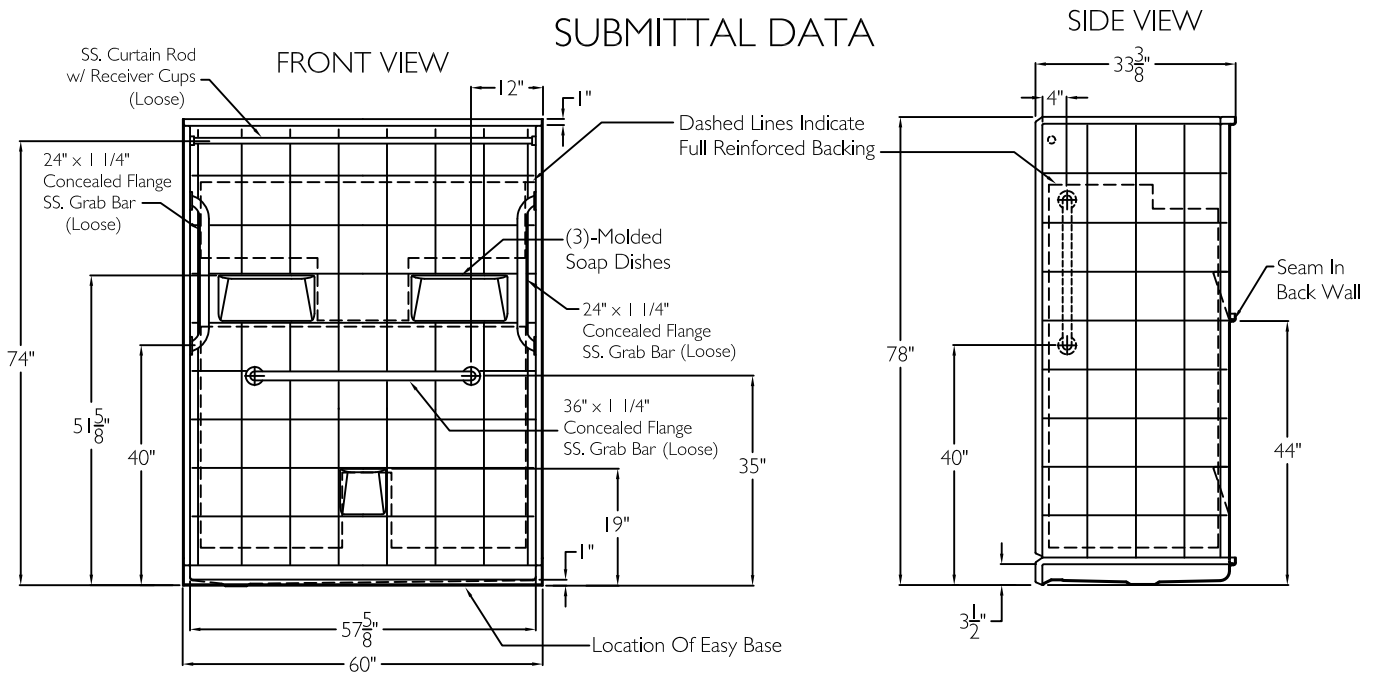

5 Piece Sectional BF Shower

The sectional shower shall be model LM 6033 BF 5 Piece left drain. Finished surface shall be of a sanitary grade applied acrylic.

Unit has outside dimensions of : 60" x 33 3/8" x 78".  
 The five piece shower shall meet: CSA B45.5, IAPMOZ124, HUD, FHA, and Home Innovation Research Lab.

The enclosure shall be equipped with the following installed accessories:

- 1) Tile finish on walls,
- 2) Full reinforced backing on all walls,
- 3) 5 Piece sectional design,
- 4) Three molded soap ledges on the back wall,
- 5) Seam in the back wall,
- 6) Left drain location,
- 7) Factory installed Easy Base self sustaining bottom,
- 8) Brass drain fitting,
- 9) Collapsible water retainer with end caps,
- 10) 1.0" Threshold,
- 11) Stainless steel curtain rod with receiver cups,
- 12) Weighted shower curtain,
- 13) Two 24" and one 36" stainless steel grab bars.

NOTE: UNIT SHIPPED UN-ASSEMBLED. (FIELD ASSEMBLY BY OTHERS).

TOP VIEW

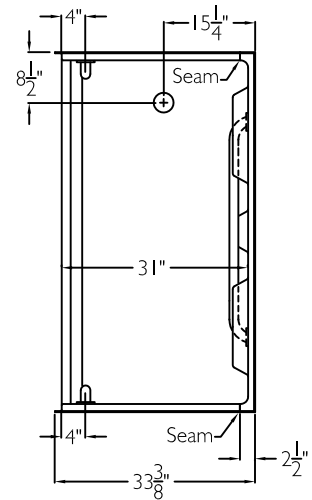

DUE TO THE NATURE OF THE MATERIALS DIMENSIONS MAY VARY + - 1/2 INCH.

LAUREL MOUNTAIN

Drawing #: LM 6033 BF 5P 1.0" CFHBW CFVSW2  
 CR FWB Easy Base

Date: 11-13-15 Revised: 5-18-17

Williston II

CROSS SECTION OF THRESHOLD

