

### 5Piece Sectional BF Shower

The sectional shower shall be model LM 6036 BF 5 Piece left drain. Finished surface shall be of a sanitary grade applied acrylic.

Unit has outside dimensions of : 60" x 36 7/8" x 78".

The five piece shower shall meet: CSA B45.5, IAPMOZI24, HUD, FHA, and Home Innovation Research Lab.

The enclosure shall be equipped with the following installed accessories:

- 1) Tile finish on walls,
- 2) Full reinforced backing on all walls,
- 3) 5 Piece sectional design,
- 4) Three molded soap ledges on the back wall,
- 5) Seam in the back wall,
- 6) Left drain location,
- 7) Factory installed Armor Core Easy Base,
- 8) Brass drain fitting,
- 9) Collapsible water retainer with end caps,
- 10) 1.0" threshold,
- 11) Two 24" and one 36" stainless steel grab bars,
- 12) Padded 24" x 16" fold up seat with legs - 1000 lb capacity
- 13) Stainless steel curtain rod with receiver cups,
- 14) Weighted shower curtain.

NOTE: UNIT SHIPPED UN-ASSEMBLED. (FIELD ASSEMBLY BY OTHERS).

### TOP VIEW

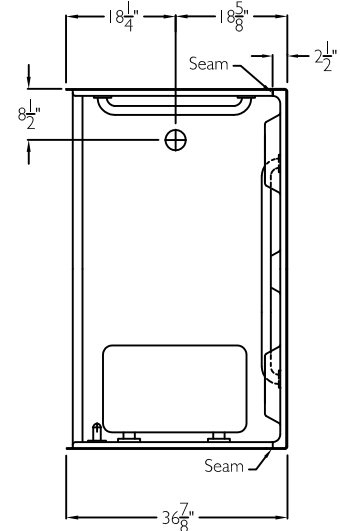

DUE TO THE NATURE OF THE MATERIALS DIMENSIONS MAY VARY + - 1/2 INCH.

## LAUREL MOUNTAIN

Drawing #: LM 6036 BF 5P 1.0" CFHBW CFHSW CFVSW  
CR Bariatric PD FWB Easy Base Left

Date: 11-11-15

Revised: 5-18-17

Gleason III

LAUREL MOUNTAIN

26 Nesbitt Road Suite 257 New Castle, Pa. 16105

Phone: 1 800 930 0050 Fax: 1 800 930 0051 Email: sales@lmbath.com