



WILLISTON I
60 x 33 3/8 x 77 3/4
Zero Threshold Shower

Drain	Model #
RH	LM6033BF5PR1.0064
LH	LM6033BF5PL1.0064

Features

- Barrier free, easy entry, wheelchair accessible threshold.
- Patented, pre-leveled base with **ArmorCore** reinforcement, and textured finish floor.
- Includes collapsible dam with end caps, stainless steel curtain rod, weighted shower curtain, chrome plated brass drain, and 3 integral shelves.
- Simple, easy 5 piece installation from front or rear
- Accommodates a shower door
- Full wood reinforced walls for extra strength that enables bars to be located to fit your individual needs.
- Premium, durable applied acrylic/fiberglass construction
- High Gloss 6" tile pattern with Diamond Accents
- Attractive and easy to clean
- Meets or exceeds UPC, IPC, ANSI Z124.1, NAHB, & SBC
- Made in the USA with a lifetime limited warranty

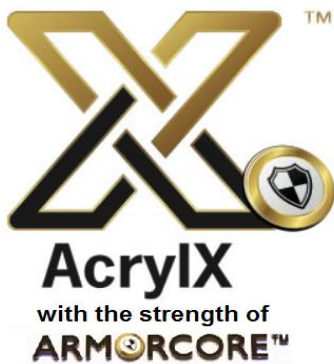

ARMORCORE

Tested to IAPMO standards to withstand more than **6X** the standard pressure without failure



THRESHOLD

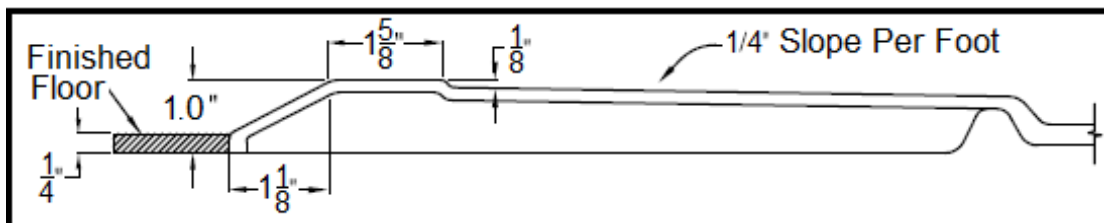

SUBMITTAL DATA

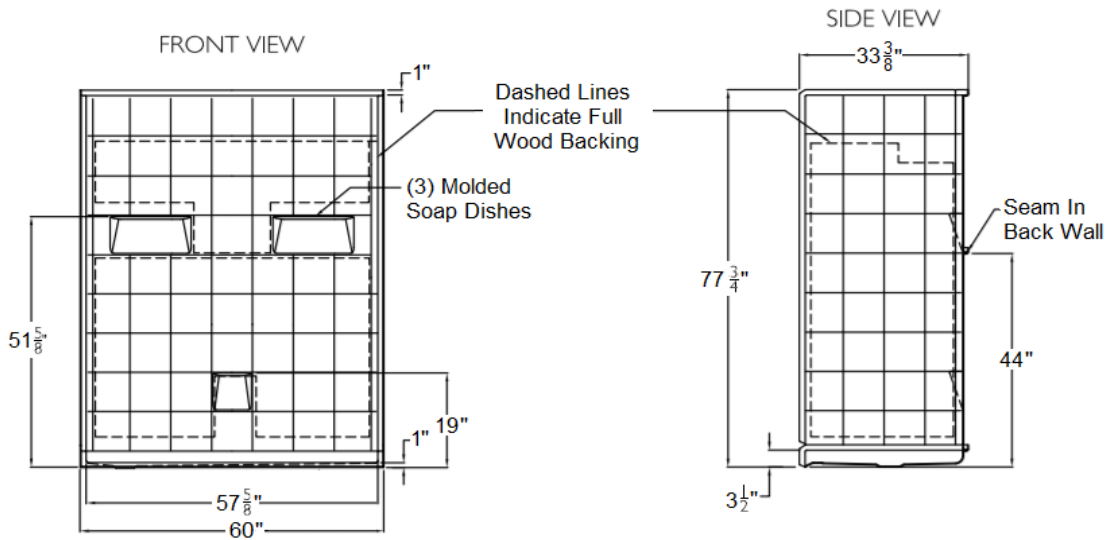

5 Piece Sectional BF Shower

The sectional shower shall be model LM6033BF5 Piece right or left drain. Finished surface shall be of a sanitary grade polyester applied acrylic, exhibiting a minimal thickness of 15 dry mils, and a finished cured Barcoal hardness of 80-90 as tested with ASTM D-2583. Unit construction shall be of molded reinforced fiberglass with a minimum 15% fiberglass content.

Unit has outside dimension of: 60" x 33" x 77 3/4"
 The five piece shower shall meet: CSA B45.5, IAPMOZ124, HUD, FHA, Home Innovation Research Lab, and shall meet the requirements of the Southern Building Code.

The enclosure shall be equipped with the following accessories:

- 1) Tile finish on walls,
- 2) Full wood backing on walls,
- 3) 5 Piece sectional design,
- 4) Three molded soap ledges on the back wall,
- 5) Seam in the back wall,
- 6) Right or left drain location,
- 7) Brass drain fitting,
- 8) Collapsible water retainer with end caps,
- 9) 1.0" threshold,
- 10) Stainless steel curtain rod with receiver cups,
- 11) Premium weighted shower curtain.

NOTE: UNIT SHIPPED UN-ASSEMBLED, (FIELD ASSEMBLY BY OTHERS)

TOP VIEW

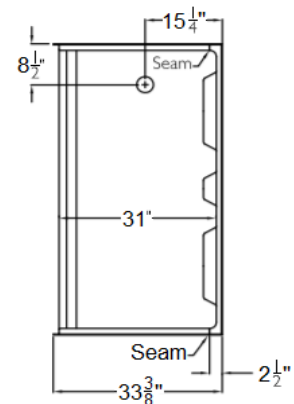

CROSS SECTION OF THRESHOLD

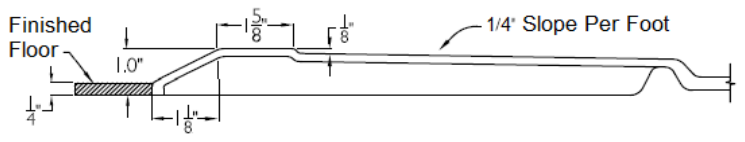

DUE TO THE NATURE OF THE MATERIALS DIMENSIONS MAY VARY + - 1/2 INCH.

LAUREL MOUNTAIN

Drawing #: LM 6033 BF 5P 1.0"

Date: 11-1-0-15

Revised: 1 - 5 - 19

Williston I

LAUREL MOUNTAIN

26 Nesbitt Road Suite 257 New Castle, Pa, 16105

Phone: 1 800 930 0050 Fax: 1 800 930 0051 Email: sales@lmbath.com